

REVISION HISTORY			
REV.	DESCRIPTION	DATE	DRAWN BY
1	ORIGINAL PRINT	5/10/2022	N. LAWRENCE

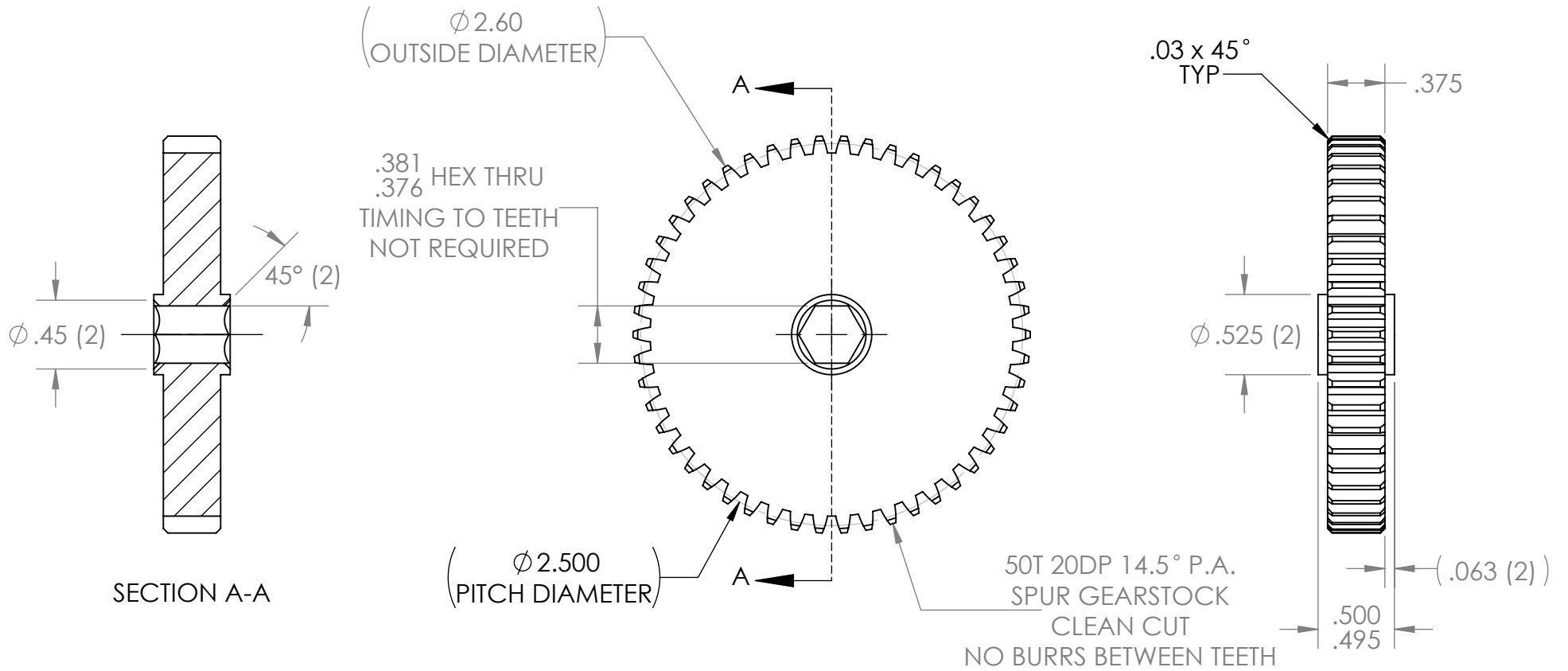

\*\*\* SEE CAD FOR ADDITIONAL TOOLPATH INFO\*\*\*

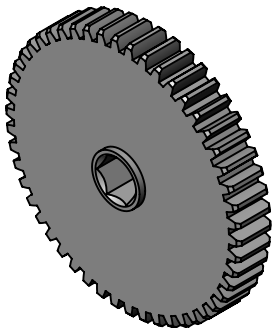

UNLESS OTHERWISE SPECIFIED:		COMMENTS:					
<b>DIMENSIONS ARE IN INCHES</b>		DUAL DIMENSIONS ARE IN MILLIMETERS.					TITLE:
TOLERANCES: FRACTIONAL $\pm 1/16$ ANGULAR: MACH $\pm 1^\circ$ ANGULAR: BEND $\pm 5^\circ$ ONE PLACE DECIMAL $\pm 0.1$ TWO PLACE DECIMAL $\pm 0.01$ THREE PLACE DECIMAL $\pm 0.005$ FOUR PLACE DECIMAL $\pm 0.0005$		BREAK ALL SHARP EDGES.		50T 20DP 14.5PA 0.375IN HEX BORE GEAR			
MATERIAL 4140 STEEL		CHECKED	NAME NM	DATE	SIZE <b>A</b>	DWG. NO. am-4720	REV 1
FINISH DEBURRED ZINC PLATED		ENG APPR.			SCALE: 1:1		
DO NOT SCALE DRAWING		MFG APPR.			SHEET 1 OF 1		
		Q.A.					